

FMS-webMASTER 020

Stepper motor design

High precision at high machine speed

Roller length from 250 to 600 mm

Designed for narrow web application

Compact and robust design

Reliable and maintenance free operation



● FMS-webMASTER 020

The steering frames of the FMS-webMASTER 020 Series have been especially developed for use in narrow web applications such as: label printing presses, small slitters and rewinders, film conversions, small packaging lines, etc. They are characterized by a compact and robust construction and are available with the controller integrated into the frame on either side.

The FMS-webMASTER 020 has an integrated mounting bar for one or two sensors. The sensors are attached to the bar by movable brackets. All the analogue and digital sensors of the FMS product family can be used for edge guiding, center guiding and line guiding operation.

The frame is pre-wired and requires only a single power supply.

The adjustment of the upper part of the frame that supports the rollers is made by a powerful stepper motor with a ball screw. The rollers are manufactured and balanced according to the customer's specification. FMS web guide controllers of the serie BKS 110 or of the serie BKS 600 can be combined with the steering frame. The BKS 110 controller is integrated into the side of the steering frame as standard. Robust and compact aluminium housing is also available.

FMS-webMASTER 020 • Dimensions in mm

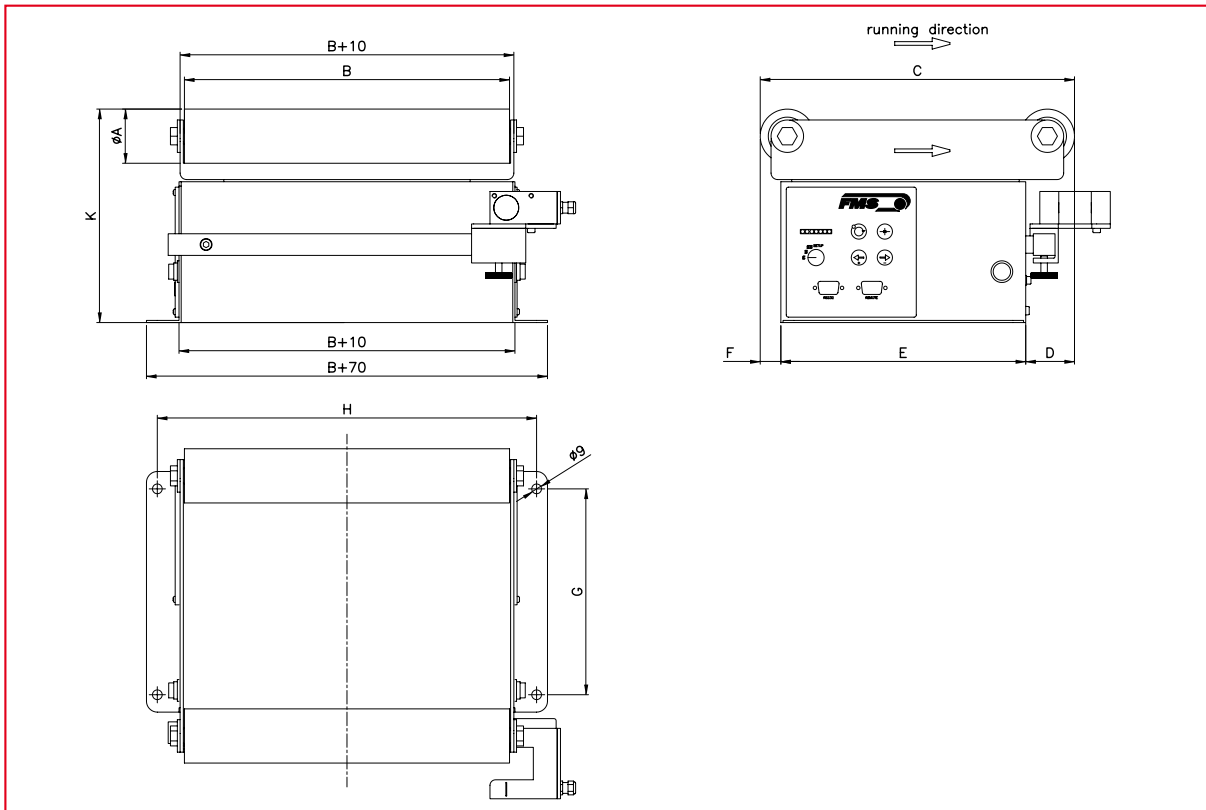

FMS-webMASTER 020 • Dimensions in mm

FMS-webMASTER Type	A	B	C	K	D	E	F	G	H	AL 1)
BKS 020.3.0250.0280.050	50	250	280	197	45	226	9	190	300	± 15
BKS 020.3.0300.0290.050	50	300	290	197	45	226	19	190	350	± 25
BKS 020.3.0400.0320.075	75	400	320	197	45	251	24	215	450	± 25
BKS 020.3.0500.0405.075	75	500	405	222	45	336	24	300	550	± 25
BKS 020.3.0600.0455.075	75	600	455	222	45	386	24	350	650	± 25

1) AL = Correction

Other sizes on request, maximum roller length = 600 mm

FMS-webMASTER 020 • Technical data

Upper part bearing	3-point (B 500: 5-point)
Adjusting speed	> 35 mm / s
Drive	With ball screw and stepper motor, 24 V / max. 2.5 A
Temperature range	0...60 °C
Protection class	IP 30

**Order code (example):
FMS-webMASTER 020**

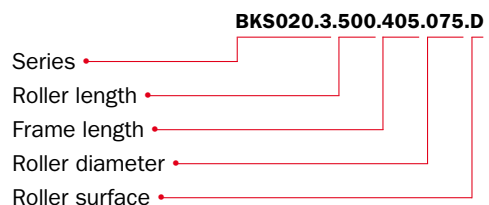

World Headquarters:

FMS Force Measuring Systems AG
 Aspstrasse 6
 8154 Oberglatt (Switzerland)
 Phone + 41 44 852 80 80
 Fax + 41 44 850 60 06
 info@fms-technology.com

FMS USA, Inc.
 2155 Stonington Avenue
 Suite 119
 Hoffman Estates, IL 60169
 Phone + 1 847 519 4400
 Fax + 1 847 519 4401
 fmsusa@fms-technology.com

FMS UK
 Highfield, Atch Lench Road
 Church Lench
 Evesham WR 11 4UG
 Phone + 44 1386 871023
 Fax + 44 1386 871021
 fmsuk@fms-technology.com

FMS Italy
 Via Baranzate 67
 20026 Novate Milanese
 Phone + 39 02 39487035
 Fax + 39 02 39487035
 fmsit@fms-technology.com